

RX

Customised to your machine

- Up to 132 kW
- High starting torque in open loop: 200% at 0.3Hz
- Full torque at 0 Hz in closed loop
- Sensor-less and vector closed-loop control
- Built-in EMC filter
- Built-in logic programmability
- Built-in application functionality
- Positioning functionality
- Automatic energy saving
- Micro-surge voltage suppression
- Modbus RS485 (options for other networks)
- CE, cULus, RoHS

Ratings

- 200 V Class three-phase 0.4 to 55 kW
- 400 V Class three-phase 0.4 to 132 kW



System configuration

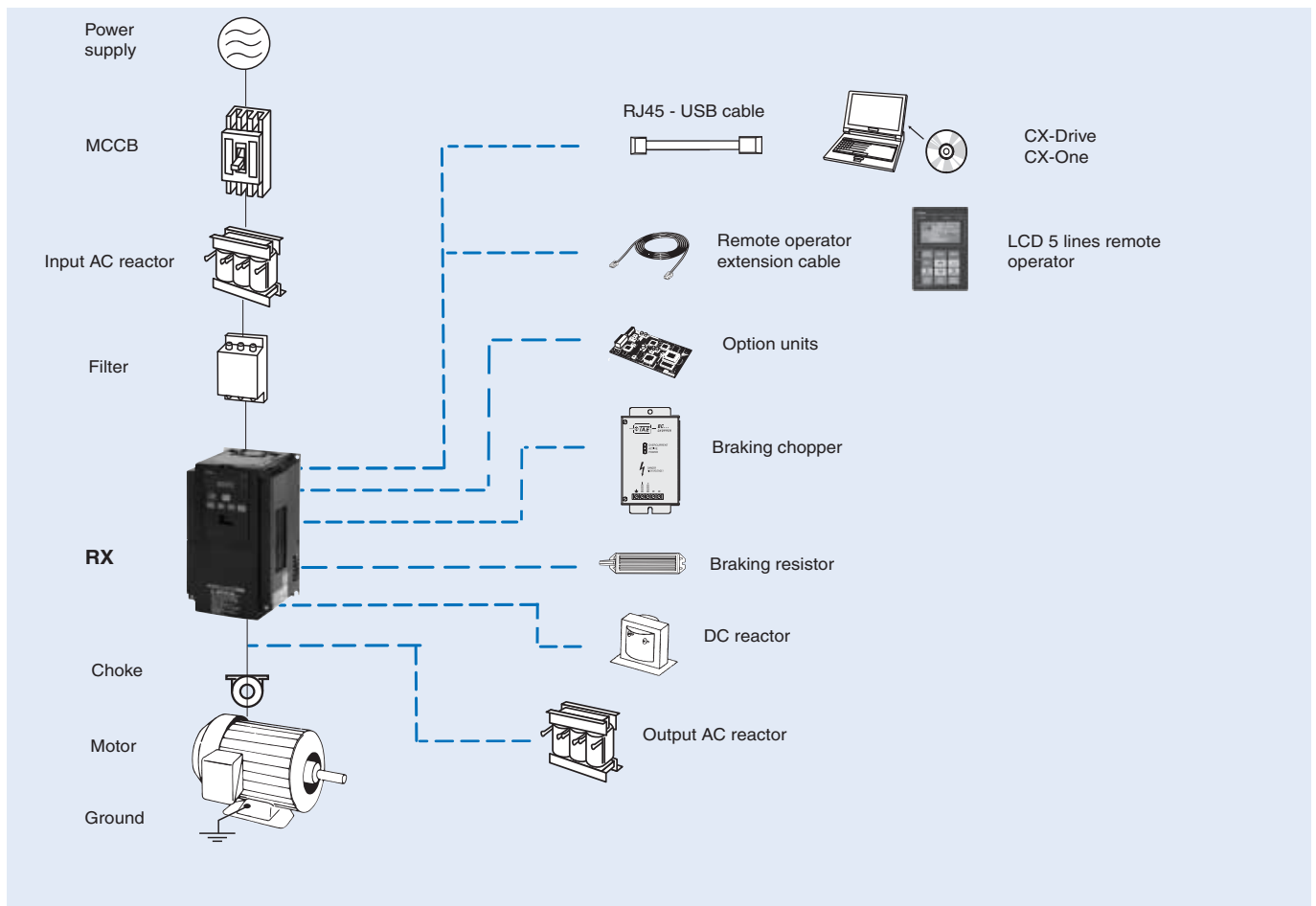

Specifications

Type designation

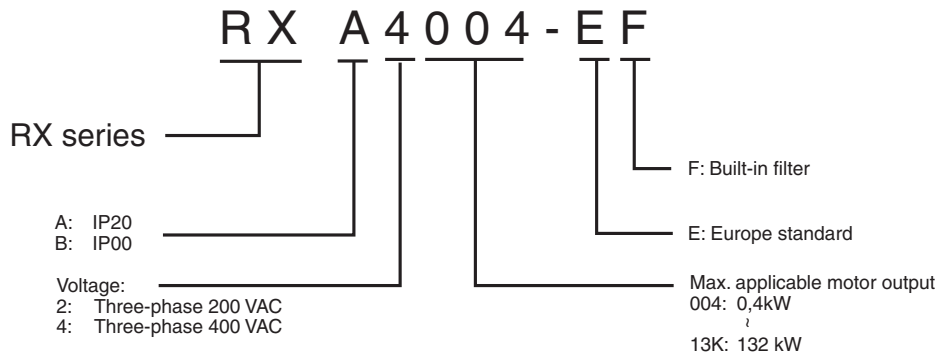

200 V class

Three-phase: RX-□		A2004	A2007	A2015	A2022	A2037	A2055	A2075	A2110	A2150	A2185	A2220	A2300	A2370	A2450	A2550		
Motor kW ^{*1}		0.4	0.75	1.5	2.2	4.0	5.5	7.5	11	15	18.5	22	30	37	45	55		
Output characteristics	Inverter capacity kVA	200 V		1.0	1.7	2.5	3.6	5.7	8.3	11.0	15.9	22.1	26.3	32.9	41.9	50.2	63.0	76.2
		240 V		1.2	2.0	3.1	4.3	6.8	9.9	13.3	19.1	26.6	31.5	39.4	50.2	60.2	75.6	91.4
Rated output current (A)		3.0	5.0	7.5	10.5	16.5	24	32	46	64	76	95	121	145	182	220		
Max. output voltage		Proportional to input voltage: 0..240 V																
Max. output frequency		400 Hz																
Rated input voltage and frequency		3-phase 200..240 V 50/60 Hz																
Allowable voltage fluctuation		-15%..+10%																
Allowable frequency fluctuation		5%																
Braking	Regenerative braking	Internal BRD circuit (external discharge resistor)												External regenerative braking unit				
	Minimum connectable resistance	50	50	35	35	35	16	10	10	7.5	7.5	5						
Protective structure		IP20																
Cooling method		Forced air cooling																

*1 Based on a standard 3-Phase standard motor.

400V class

Three-phase: RX-□		A4004	A4007	A4015	A4022	A4040	A4055	A4075	A4110	A4150	A4185	A4220	A4300	A4370	A4450	A4550	B4750	B4900	B411K	B413K		
Motor kW ^{*1}		0.4	0.75	1.5	2.2	4.0	5.5	7.5	11	15	18.5	22	30	37	45	55	75	90	110	132		
Output characteristics	Inverter capacity kVA	400 V		1.0	1.7	2.5	3.6	6.2	9.7	13.1	17.3	22.1	26.3	33.2	40.1	51.9	63.0	77.6	103.2	121.9	150.3	180.1
		480 V		1.2	2.0	3.1	4.3	7.4	11.6	15.8	20.7	26.6	31.5	39.9	48.2	62.3	75.6	93.1	123.8	146.3	180.4	216.1
Rated output current (A)		1.5	2.5	3.8	5.3	9.0	14	19	25	32	38	48	58	75	91	112	149	176	217	260		
Max. output voltage		Proportional to input voltage: 0..480 V																				
Max. output frequency		400 Hz																				
Rated input voltage and frequency		3-phase 380..480 V 50/60 Hz																				
Allowable voltage fluctuation		-15%..+10%																				
Allowable frequency fluctuation		5%																				
Braking	Regenerative braking	Internal BRD circuit (external discharge resistor)												External regenerative braking unit								
	Minimum connectable resistance	100	100	100	100	70	70	35	35	24	24	20										
Protective structure		IP20															IP00					
Cooling method		Forced air cooling																				

*1 Based on a standard 3-Phase standard motor.

Common specifications

Model number RX□		Specifications	
Control functions	Control methods	Phase-to-phase sinusoidal pulse with modulation PWM (Sensorless vector control, close loop vector with motor feedback, V/F)	
	Output frequency range	0.10 to 400.00 Hz	
	Frequency precision	Digital set value: ±0.01% of the max. frequency	
		Analogue set value: ±0.2% of the max. frequency (25 ±10 °C)	
	Resolution of frequency set value	Digital set value: 0.01 Hz Analogue input: 12 bit	
	Resolution of output frequency	0.01Hz	
	Starting torque	150%/0.3 Hz (under sensor-less vector control or sensor-less vector control at 0 Hz)	
		200%/Torque at 0 Hz (under sensor-less vector control at 0Hz, when a motor size one rank lower than specified is connected)	
	Overload capability	150%/60 s, 200%/3 s	
Frequency set value	0 to 10 VDC (10 KΩ), -10 to 10 VDC (10 KΩ), 4 to 20 mA (100 Ω), RS485 Modbus, Network options		
V/f Characteristics	V/f optionally changeable at base frequencies of 30 to 400 Hz, V/f braking constant torque, reduction torque, sensor-less vector control, sensor-less vector control at 0 Hz		
Functionality	Inputs signals	8 terminals, NO/NC switchable, sink/source logic switchable [Terminal function] 8 functions can be selected from among 61. Reverse (RV), Multi-step speed setting binary 1 (CF1), Multi-step speed setting binary 2 (CF2), Multi-step speed setting binary 3 (CF3), Multi-step speed setting binary 4 (CF4), Jogging (JG), DC injection braking (DB), 2nd control (SET), 2-step acceleration/deceleration (2CH), Free-run stop (FRS), External trip (EXT), USP function (USP), Commercial switching (CS), Soft lock (SFT), Analog input switching (AT), 3rd control (SET3), Reset (RS), 3-wire start (STA), 3-wire stop (STP), 3-wire forward/reverse (F/R), PID enabled/disabled (PID), PID integral reset (PIDC), Control gain switching (CAS), UP/DWN function accelerated (UP), UP/DWN function decelerated (DWN), UP/DWN function data clear (UDC), Forced operator (OPE), Multi-step speed setting bit 1 (SF1), Multi-step speed setting bit 2 (SF2), Multi-step speed setting bit 3 (SF3), Multi-step speed setting bit 4 (SF4), Multi-step speed setting bit 5 (SF5), Multi-step speed setting bit 6 (SF6), Multi-step speed setting bit 7 (SF7), Overload limit switching (OLR), Torque limit enabled (TL), Torque limit switching 1 (TRQ1), Torque limit switching 2 (TRQ2), P/PI switching (PPI), Brake confirmation (BOK), Orientation (ORT), LAD cancel (LAC), Position deviation clear (PCLR), Pulse train position command input permission (STAT), Frequency addition function (ADD), Forced terminal block (F-TM), Torque reference input permission (ATR), Integrated power clear (KHC), Servo ON (SON), Preliminary excitation (FOC), Analog command on hold (AHD), Position command selection 1 (CP1), Position command selection 2 (CP2), Position command selection 3 (CP3), Zero return limit signal (ORL), Zero return startup signal (ORG), Forward driving stop (FOT), Reverse driving stop (ROT), Speed/Position switching (SPD), Pulse counter (PCNT), Pulse counter clear (PCC), No allocation (no)	
	Output signals	5 open collector output terminals: NO/NC switchable, sink/source logic switchable 1 relay (SPDT contact) output terminal: NO/NC switchable [Terminal function] 6 functions can be selected from among 45. Signal during RUN (RUN), Constant speed arrival signal (FA1), Over set frequency arrival signal (FA2), Overload warning (OL), Excessive PID deviation (OD), Alarm signal (AL), Set-frequency-only arrival signal (FA3), Overtorque (OTQ), Signal during momentary power interruption (IP), Signal during undervoltage (UV), Torque limit (TRQ), RUN time exceeded (RNT), Power ON time exceeded (ONT), Thermal warning (THM), Brake release (BRK), Brake error (BER), 0-Hz signal (ZS), Excessive speed deviation (DSE), Position ready (POK), Set frequency exceeded 2 (FA4), Set frequency only 2 (FA5), Overload warning 2 (OL2), Analog FV disconnection detection (FVDC), Analog FI disconnection detection (FIDC), Analog FE disconnection detection (FEDC), PID FB status output (FBV), Network error (NDC), Logic operation output 1 (LOG1), Logic operation output 2 (LOG2), Logic operation output 3 (LOG3), Logic operation output 4 (LOG4), Logic operation output 5 (LOG5), Logic operation output 6 (LOG6), Capacitor life warning (WAC), Cooling fan life warning (WAF), Starting contact signal (FR), Fin overheat warning (OHF), Light load detection signal (LOC), Operation ready (IRDY), Forward run (FWR), Reverse run (RVR), Fatal fault (MJA), Window comparator FV (WCFV), Window comparator FI (WCFI), Window comparator FE (WCFE), Alarm codes 0 to 3 (AC0 to AC3)	
	Standard functions	V/f free setting (7), Upper/lower frequency limit, Frequency jump, Curve acceleration/deceleration, Manual torque boost level/break, Energy-saving operation, Analog meter adjustment, Starting frequency, Carrier frequency adjustment, Electronic thermal function, (free setting available), External start/end (frequency/rate), Analog input selection, Trip retry, Restart during momentary power interruption, Various signal outputs, Reduced voltage startup, Overload limit, Initialization value setting, Automatic deceleration at power-off, AVR function, Automatic acceleration/deceleration, Auto tuning (Online/Offline), High torque multi-motor operation control (sensor-less vector control of two monitors with one inverter)	
	Analogue inputs	Analogue inputs 0 to 10 V and -10 to 10 V (10 KΩ), 4 to 20 mA (100 Ω)	
	Analogue outputs	Analogue voltage output, Analog current output, Pulse train output	
	Accel/Decel times	0.01 to 3600.0 s (line/curve selection)	
	Display	Status indicator LED's Run, Program, Power, Alarm, Hz, Amps, Volts, % Digital operator: Available to monitor 23 items, output current, output frequency...	
	Protection functions	Motor overload protection	Electronic Thermal overload relay and PTC thermistor input
		Instantaneous overcurrent	200% of rated current for 3 seconds
		Overload	150% for 1 minute
Overvoltage		800 V for 400 V type and 400 V for 200 V type	
Momentary power loss		Decelerates to stop with DC bus controlled, coast to stop	
Cooling fin overheat		Temperature monitor and error detection	
Stall prevention level		Stall prevention during acceleration, deceleration and constant speed	
Ground fault		Detection at power on	
Ambient conditions	Power charge indication	On when voltage between P and N is higher than 45V	
	Degree of protection	IP20 / IP00	
	Ambient humidity	90% RH or less (without condensation)	
	Storage temperature	-20°C..+65°C (short-term temperature during transportation)	
	Ambient temperature	-10°C to 50°C	
	Installation	Indoor (no corrosive gas, dust, etc.)	
	Installation height	Max. 1000 m	
Vibration	RX-A□004 to A□220, 5.9 m/s ² (0.6G), 10 to 55 Hz RX-A□300 to B□13K, 2.94 m/s ² (0.3G), 10 to 55 Hz		

Dimensions

Figure 1

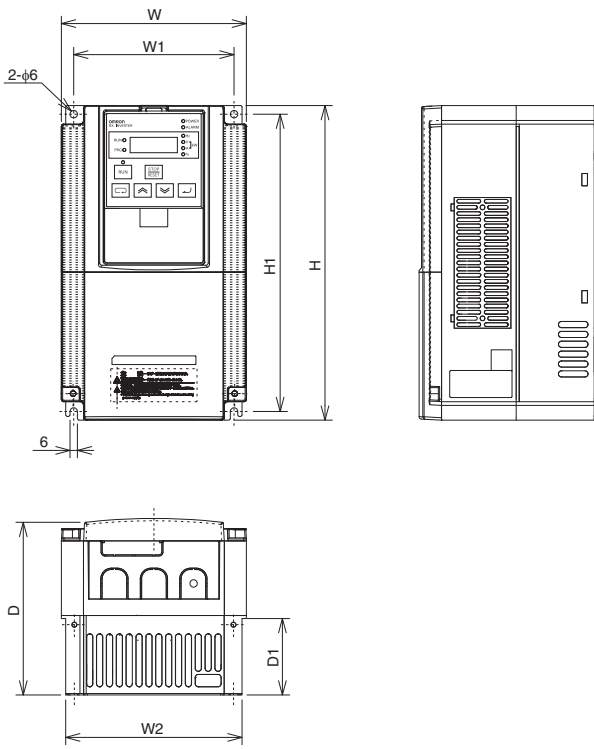

Figure 2

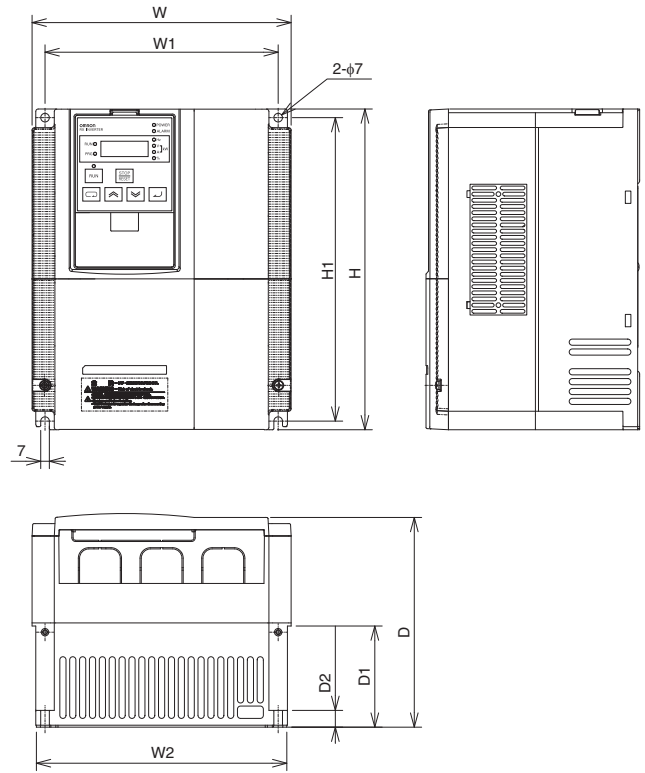

Figure 3

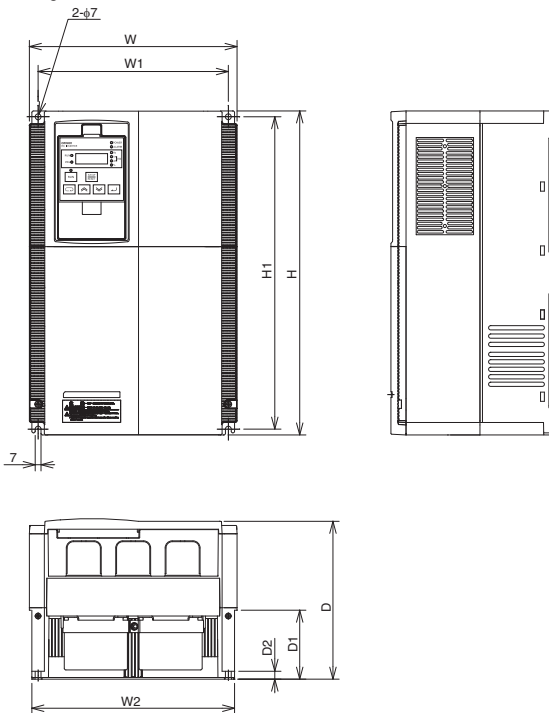

Figure 4

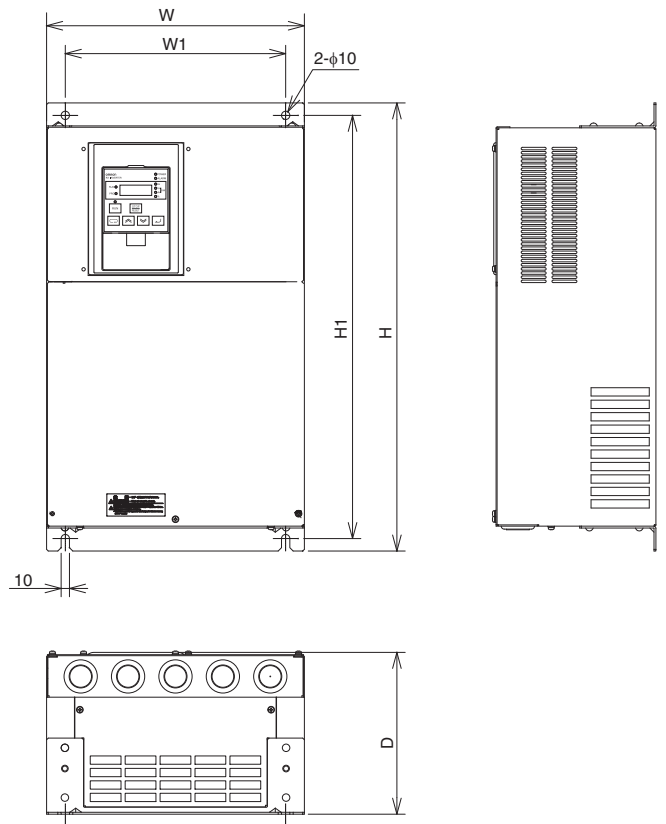
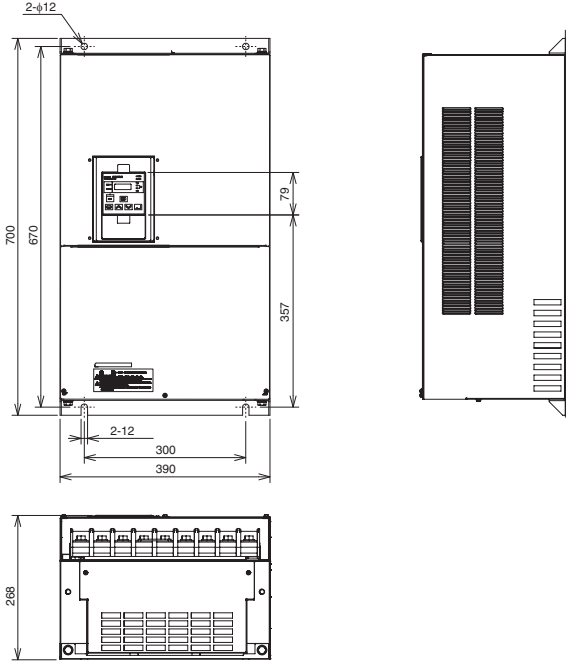
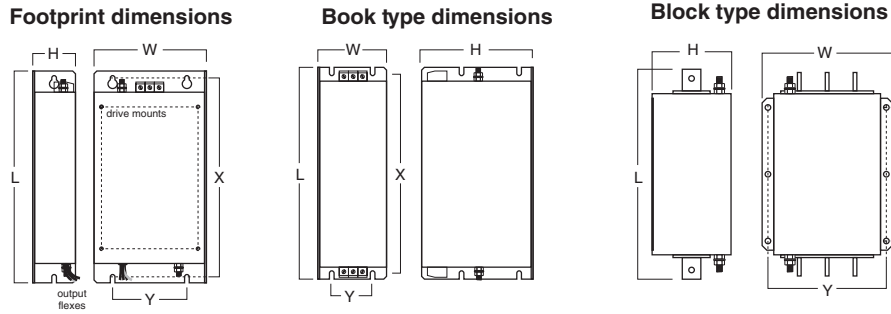

Figure 5



Voltage class	Inverter model RX□	Figure	Dimensions in mm								Weight (KG)
			W	W1	W2	H	H1	D	D1	D2	
Three-phase 200 V	A2004	1	150	130	143	255	241	140	62	-	3.5
	A2007										
	A2015										
	A2022										
	A2037										
	A2055	2	210	189	203	260	246	170	82	13.6	6
	A2075										
	A2110										
	A2150	3	250	229	244	390	376	190	83	9.5	14
	A2185										
	A2220										
	A2300	4	310	265	-	540	510	195	-	-	20
A2370	390		300	-	550	520	250	-	-	30	
A2450	480		380	-	700	670	250	-	-	43	
A2550											
Three-phase 400 V	A4004	1	150	130	143	255	241	140	62	-	3.5
	A4007										
	A4015										
	A4022										
	A4040										
	A4055	2	210	189	203	260	246	170	82	13.6	6
	A4075										
	A4110										
	A4150	3	250	229	244	390	376	190	83	9.5	14
	A4185										
	A4220										
	A4300	4	310	265	-	540	510	195	-	-	22
	A4370		390	300	-	550	520	250	-	-	30
	A4450										
	A4550										
	B4750	5	390	300	-	700	670	268	-	-	60
B4900											
B411K	480		380	-	740	710	270	-	-	80	
B413K											

Rasmi filters



Voltage	Inverter model	Rasmi model	Dimensions						Filter type	Weight KG
			L	W	H	X	Y	M		
3x200 V	RX-A2004	AX-FIR2018-RE	305	152	45	290	110	M5	Footprint	2.0
	RX-A2007									
	RX-A2015									
	RX-A2022									
	RX-A2037									
	RX-A2055	AX-FIR2053-RE	312	212	56	296	189	M6	2.5	
	RX-A2075									
	RX-A2110									
	RX-A2150	AX-FIR2110-RE	455	110	240	414	80		Book type	8.0
	RX-A2185									
	RX-A2220									
	RX-A2300	AX-FIR2145-RE								
RX-A2370	AX-FIR3250-RE	386	260	135	240	235	-		Block type	13
RX-A2450										
RX-A2550										
3x400 V	RX-A4004	AX-FIR3010-RE	305	152	45	290	110	M5	Footprint	1.9
	RX-A4007									
	RX-A4015									
	RX-A4022									
	RX-A4040									
	RX-A4055	AX-FIR3030-RE	312	212	50	296	189	M6	2.2	
	RX-A4075									
	RX-A4110									
	RX-A4150	AX-FIR3053-RE	451	252	60	435	229	M6	4.5	
	RX-A4185									
	RX-A4220									
	RX-A4300	AX-FIR3064-RE	598	310	70	578	265	M8	7.0	
	RX-A4370	AX-FIR3100-RE							8.0	
	RX-A4450	AX-FIR3130-RE	486	110	240	414	80	-	Book type	8.6
	RX-A4550									
	RX-B4750									
RX-B4900	AX-FIR3250-RE	386	260	135	240	235	-	Block type	13.0	
RX-B411K	AX-FIR3320-RE									13.2
RX-B413K										

Input AC Reactor

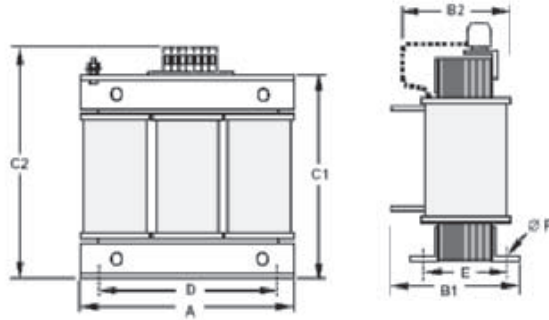

Voltage	Reference	Dimensions								Weight Kg		
		A	B1	B2	C1	C2	D	E	F			
200 V	AX-RAI02800100-DE	120	-	80	-	120	80	62	5.5	2.35		
	AX-RAI00880200-DE			85		190		55				
	AX-RAI00350335-DE	180		105	205	85	6	6.5				
	AX-RAI00180670-DE			205								
	AX-RAI00091000-DE			240	130	-		210	-	200	75	16.0
	AX-RAI00071550-DE											
400 V	AX-RAI07700050-DE	120	-	70	-	120	80	52	5.5	1.78		
	AX-RAI03500100-DE			80		62		2.35				
	AX-RAI01300170-DE			2.5								
	AX-RAI00740335-DE	180		85	190	55	6	5.5				
	AX-RAI00360500-DE			105	205				6.5			
	AX-RAI00290780-DE			240	110	275		200	75	11.7		
	AX-RAI00191150-DE											16.0

DC reactor

Figure 1

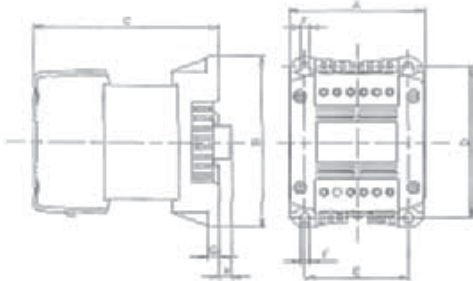
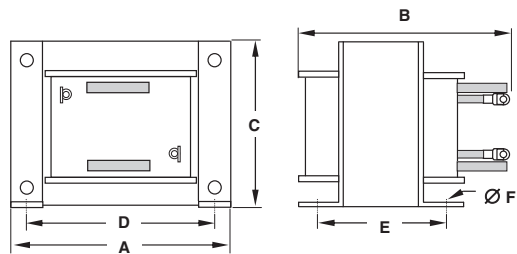
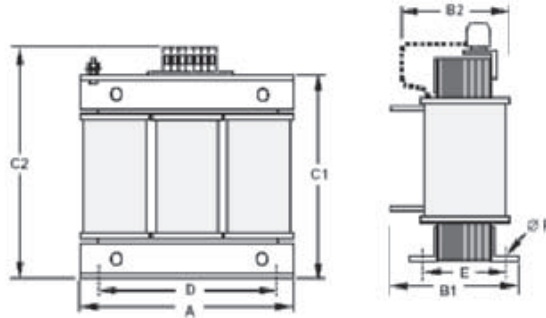

Figure 2



200 V										400 V																				
Reference AX-RC	Fig	Dimensions								kg	Reference AX-RC	Fig	Dimensions								kg									
		A	B	C	D	E	F	G	H			A	B	C	D	E	F	G	H											
21400016-DE	1	84	113	96	101	66	5	7.5	2	1.22	43000020-DE	1	84	113	96	101	66	5	7.5	2	1.22									
10700032-DE				105							27000030-DE				105															
06750061-DE				105							14000047-DE				116															
03510093-DE				116							10100069-DE				116															
02510138-DE				116							06400116-DE				133															
01600223-DE		108	135	124	120	82	6.5	9.5	3.20	04410167-DE	108		135	133	120	82	6.5	9.5	3.70											
01110309-DE		120	152	136	135	94	7	9.5	-	5.20	03350219-DE		120	152	136	135	94	7	9.5	-	5.20	04410167-DE	120	152	146	135	94	7	9.5	6.00
00840437-DE				146							02330307-DE				160															
00590614-DE				160							01750430-DE				182.6															
00440859-DE		150	177	160	160	115	7	2	11.4	01750430-DE	150		177	182.6	160	115	7	2	14.3											
00301275-DE	2	195	161	162.5	185	88	10	-	17.0	01200644-DE	2	195	161	162.5	185	88	10	-	17.0	01200644-DE	195	196	123	185	109	-	-	17.0		
00231662-DE			123							00741042-DE			188																	
00192015-DE			188							00611236-DE			198																	
00162500-DE			198							00501529-DE			228																	
00133057-DE		240	198	200	228	119	12	38.0	00501529-DE	240		198	200	228	119	12	42.0													
			228		149			42.0						228		149														

Output AC reactor



Reference	Dimensions						Weight kg
	A	B2	C2	D	E	F	
AX-RAO11500026-DE	120	70	120	80	52	5.5	1.78
AX-RAO07600042-DE	120	70	120	80	52	5.5	1.78
AX-RAO04100075-DE	120	80	120	80	62	5.5	2.35
AX-RAO03000105-DE	120	80	120	80	62	5.5	2.35
AX-RAO01830180-DE	180	85	190	140	55	6	5.5
AX-RAO01150220-DE	180	85	190	140	55	6	5.5
AX-RAO00950320-DE	180	85	205	140	55	6	6.5
AX-RAO00630430-DE	180	95	205	140	65	6	9.1
AX-RAO00490640-DE	180	95	205	140	65	6	9.1
AX-RAO16300038-DE	120	70	120	80	52	5.5	1.78
AX-RAO11800053-DE	120	80	120	80	52	5.5	2.35
AX-RAO07300080-DE	120	80	120	80	62	5.5	2.35
AX-RAO04600110-DE	180	85	190	140	55	6	5.5
AX-RAO03600160-DE	180	85	205	140	55	6	6.5
AX-RAO02500220-DE	180	95	205	140	55	6	9.1
AX-RAO02000320-DE	180	105	205	140	85	6	11.7

Chokes

Reference	D diameter	Motor KW	Dimensions						Weight kg
			L	W	H	X	Y	m	
AX-FER2102-RE	21	< 2.2	85	22	46	70	-	5	0.1
AX-FER2515-RE	25	< 15	105	25	62	90	-	5	0.2
AX-FER5045-RE	50	< 45	150	50	110	125	30	5	0.7
AX-FER6055-RE	60	> 45	200	65	170	180	45	6	1.7

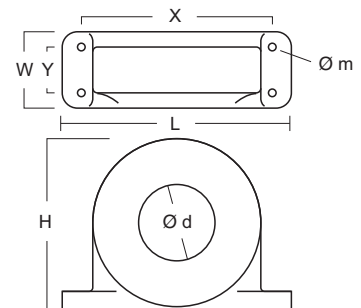

Braking unit dimensions

Reference	Dimensions					
	B	B1	H	H1	T	S
AX-BCR4015045-TE	82.5	40.5	150	138	220	6
AX-BCR4017068-TE						
AX-BCR2035090-TE	130	64.5	205	193	208	6
AX-BCR2070130-TE						
AX-BCR4035090-TE						
AX-BCR4070130-TE	131	64.5	298	280	300	9
AX-BCR4090240-TE						

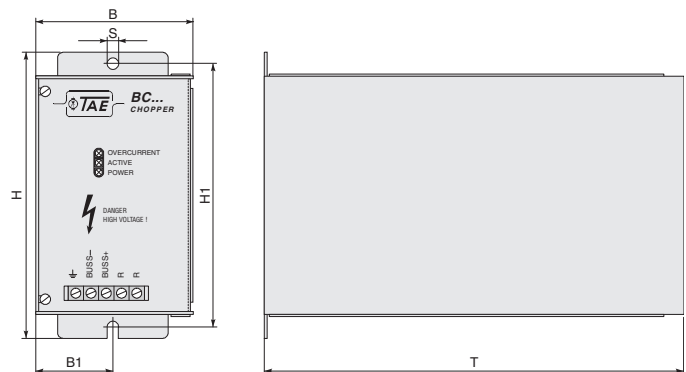

Resistor dimensions

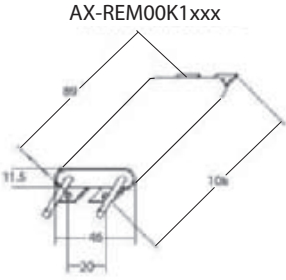

Fig 1

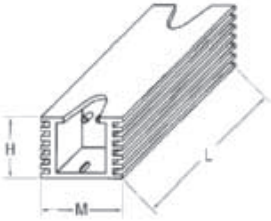

Fig 2

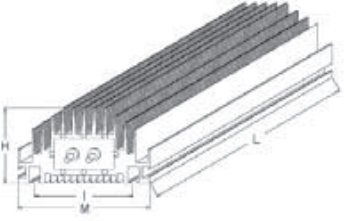

Fig 3

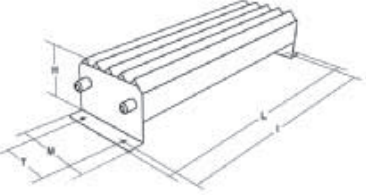

Fig 4

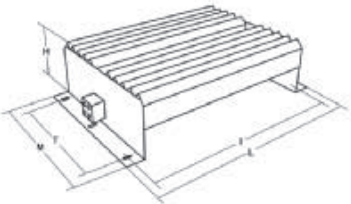
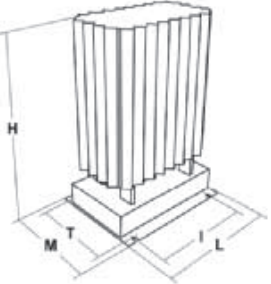
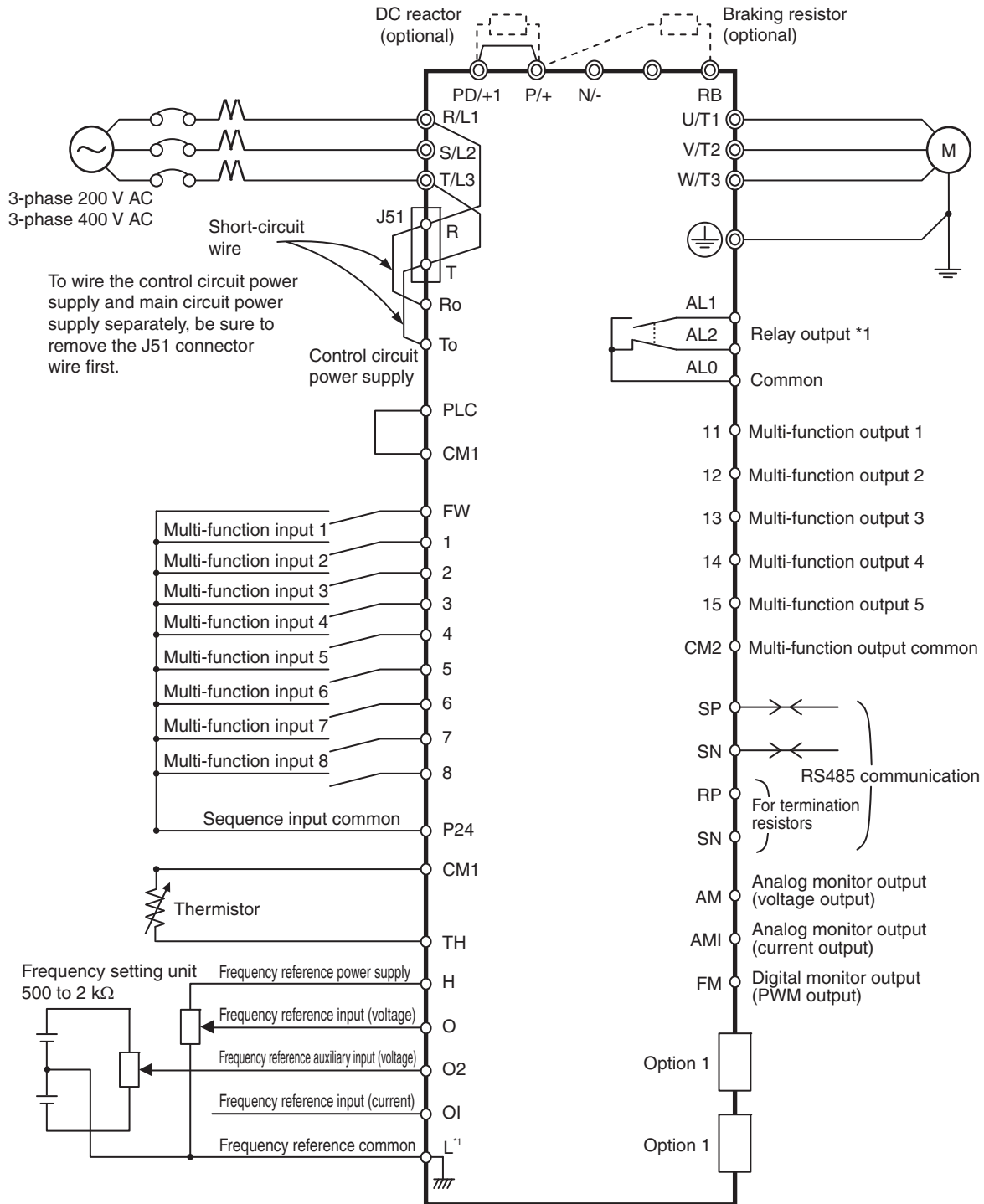

Fig 5



Type	Fig.	Dimensions					Weight kg
		L	H	M	I	T	
AX-REM00K2070-IE	1	105	27	36	94	-	0.2
AX-REM00K2120-IE							
AX-REM00K2200-IE							
AX-REM00K4075-IE							
AX-REM00K4035-IE							
AX-REM00K4030-IE							
AX-REM00K5120-IE							
AX-REM00K6100-IE							
AX-REM00K6035-IE	2	200	62	100	74	-	1.41
AX-REM00K9070-IE							
AX-REM00K9020-IE							
AX-REM00K9017-IE	3	365	73	105	350	70	4
AX-REM01K9017-IE							
AX-REM02K1070-IE	4	310	100	240	295	210	7
AX-REM02K1017-IE							
AX-REM03K5035-IE							
AX-REM03K5010-IE	5	206	350	140	190	50	8.1
AX-REM19K0006-IE							
AX-REM19K0008-IE							
AX-REM19K0020-IE							
AX-REM19K0030-IE							
AX-REM38K0012-IE							

Standard connections



*1 L is the common reference for analog input and also for analog output.

Terminal block specifications

Terminal	Name	Function (signal level)
R/L1, S/L2, T/L3	Main circuit power supply input	Used to connect line power to the drive.
U/T1, V/T2, W/T3	Inverter output	Used to connect the motor
PD/+1, P/+	External DC reactor terminal	Normally connected by the short-circuit bar. Remove the short-circuit bar between +1 and P/+2 when a DC reactor is connected.
P/+, RB	Braking resistor connection terminals	Connect option braking resistor (if a braking torque is required)
P/+, N/-	Regenerative braking unit connection terminal	Connect optional regenerative braking units.
⊕	Grounding	For grounding (grounding should conform to the local grounding code.)

Control circuit

Type	No.	Signal name	Function	Signal level
Frequency reference input	H	Frequency reference power supply	10 VDC 20 mA max	
	O	Voltage frequency reference input	0 to 12 VDC (10 kΩ)	
	O2	Voltage auxiliary frequency reference	0 to +/- 12 VDC (10 kΩ)	
	OI	Current frequency reference input	4 to 20 mA (100 Ω)	
	L	Frequency reference common	Common terminal for analog monitor (AM, AMI) terminals	
Monitor Output	AM	Multi-function analog voltage output	Factory setting: Output frequency	2 mA max
	AMI	Multi-function analog current output	Factory setting: Output frequency	4 to 20 mA (max imp 250 Ω)
	FM	PWM monitor output	Factory setting: Output frequency	0 to 10 VDC Max 3.6 kHz
Power Supply	P24	Internal 24 VDC	Power supply for contact input signal	100 mA max
	CM1	Input common	Common terminal for P24, TH and FM digital monitor	
Function Selection	FW	Forward rotation command terminal	Motor runs in forwards direction when FW is ON	27 VDC max Input impd 4.7 kΩ Max current 5.6 mA On: 18 VDC or more
	1	Multi-function input	Factory setting: Reverse (RV)	
	2		Factory setting: External trip (EXT)	
	3		Factory setting: Reset (RS)	
	4		Factory setting: Multi-step speed reference 1 (CF1)	
	5		Factory setting: Multi-step speed reference 2 (CF2)	
	6		Factory setting: Jogging (JG)	
	7		Factory setting: Second control (SET)	
	8		Factory setting: No allocation (NO)	
PLC	Multi-function input common	Sink logic: Short-circuiting P24 and PLC Source logic: Short-circuiting PLC and CM1 With external supply remove short-circuit bar		
Status/ Factor	11	Multi-function output	Factory setting: During Run (RUN)	27 VDC max 50 mA max
	12		Factory setting: 0 Hz signal (ZS)	
	13		Factory setting: Overload warning (OL)	
	14		Factory setting: Overtorque (OTQ)	
	15		Factory setting: Constant speed arrival (FA1)	
	CM2	Multi-function output common	Common terminal for multi-function output terminals 11 to 15	
Relay output	AL1	Relay output (Normally close)	Factory setting: Alarm output (AL) Under normal operation MA-MC open MB-MC close	R load AL1-AL0 250 VAC 2 A AL2-AL0 250 VAC 1 A I load 250 VAC 0.2 A
	AL2	Relay output (Normally open)		
	AL0	Relay output common		
Sensor	TH	External thermistor input terminal	SC terminal functions as the common terminal 100 mW minimum Impedance at temperature error: 3 kΩ	0 to 8 VDC
Comms	SP	RS485 Modbus terminals	-	Differential input
	SN			
	RP	RS485 terminating resistor terminals	-	-
	SN			

Inverter heat loss

Three-phase 200 V class

Model RX-		A2004	A2007	A2015	A2022	A2037	A2055	A2075	A2110	A2150	A2185	A2220	A2300	A2370	A2450	A2550
Inverter capacity kVA	200 V	1.0	1.7	2.5	3.6	5.7	8.3	11.0	15.9	22.1	26.3	32.9	41.9	50.2	63.0	76.2
	240 V	1.2	2.0	3.1	4.3	6.8	9.9	13.3	19.1	26.6	31.5	39.4	50.2	60.2	75.6	91.4
Rated current (A)		3.0	5.0	7.5	10.5	16.5	24	32	46	64	76	95	121	145	182	220
Heat loss W	Losses at 70% load	64	76	102	127	179	242	312	435	575	698	820	1100	1345	1625	1975
	Losses at 100% load	70	88	125	160	235	325	425	600	800	975	1150	1550	1900	2300	2800
Efficiency at rated output		85.1	89.5	92.3	93.2	94.0	64.4	94.6	94.8	94.9	95.0	95.0	95.0	95.1	95.1	95.1
Cooling Method		Forced-air-cooling														

Three-phase 400 V class

Model RX-		A4004	A4007	A4015	A4022	A4040	A4055	A4075	A4110	A4150	A4185	A4220	A4300	A4370	A4450	A4550	B4750	B4900	B411K	B413K
Inverter capacity kVA	400 V	1.0	1.7	2.5	3.6	6.2	9.7	13.1	17.3	22.1	26.3	33.2	40.1	51.9	63.0	77.6	103.2	121.9	150.3	180.1
	480 V	1.2	2.0	3.1	4.3	7.4	11.6	15.8	20.7	26.6	31.5	39.9	48.2	62.3	75.6	93.1	123.8	146.3	180.4	216.1
Rated current (A)		1.5	2.5	3.8	5.3	9.0	14	19	25	32	38	48	58	75	91	112	149	176	217	260
Heat loss W	Losses at 70% load	64	76	102	127	179	242	312	435	575	698	820	1100	1345	1625	1975	2675	3375	3900	4670
	Losses at 100% load	70	88	125	160	235	325	425	600	800	975	1150	1550	1900	2300	2800	3800	4800	5550	6650
Efficiency at rated output		85.1	89.5	92.3	93.2	94.0	64.4	94.6	94.8	94.9	95.0	95.0	95.0	95.1	95.1	95.1	95.2	95.2	95.2	95.2
Cooling Method		Forced-air-cooling																		

Input AC Reactor

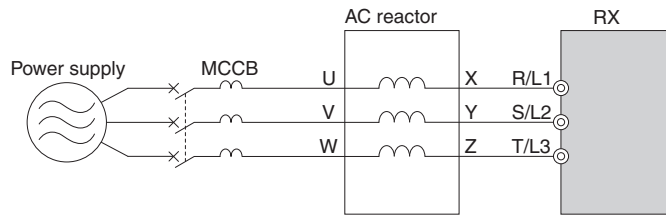

3 phase 200 V class				400 V class			
Max. applicable motor output kW	Reference	Current value A	Inductance mH	Max. applicable motor output kW	Reference	Current value A	Inductance mH
0.4 to 1.5	AX-RAI02800100-DE	10.0	2.8	0.4 to 1.5	AX-RAI07700050-DE	5.0	7.7
2.2 to 3.7	AX-RAI00880200-DE	20.0	0.88	2.2 to 3.7	AX-RAI03500100-DE	10.0	3.5
5.5 to 7.5	AX-RAI00350335-DE	33.5	0.35	5.5 to 7.5	AX-RAI01300170-DE	17.0	1.3
11.0 to 15.0	AX-RAI00180670-DE	67.0	0.18	11.0 to 15.0	AX-RAI00740335-DE	33.5	0.74
18.5 to 22.0	AX-RAI00091000-DE	100.0	0.09	18.5 to 22.0	AX-RAI00360500-DE	50.0	0.36
30.0 to 37.0	AX-RAI00071550-DE	155.0	0.07	30.0 to 37.0	AX-RAI00290780-DE	78.0	0.29
45.0 to 55.0	AX-RAI00042300-DE	230.0	0.04	45.0 to 55.0	AX-RAI00191150-DE	115.0	0.19

DC Reactor

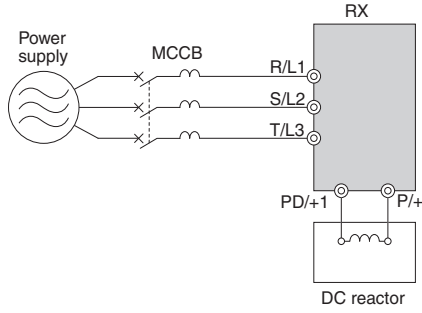

200 V class				400 V class			
Max. applicable motor output kW	Reference	Current value A	Inductance mH	Max. applicable motor output kW	Reference	Current value A	Inductance mH
0.4	AX-RC10700032-DE	3.2	10.70	0.4	AX-RC43000020-DE	2.0	43.00
0.7	AX-RC06750061-DE	6.1	6.75	0.7	AX-RC27000030-DE	3.0	27.00
1.5	AX-RC03510093-DE	9.3	3.51	1.5	AX-RC14000047-DE	4.7	14.00
2.2	AX-RC02510138-DE	13.8	2.51	2.2	AX-RC10100069-DE	6.9	10.10
3.7	AX-RC01600223-DE	22.3	1.60	4.0	AX-RC06400116-DE	11.6	6.40
5.5	AX-RC01110309-DE	30.9	1.11	5.5	AX-RC04410167-DE	16.7	4.41
7.5	AX-RC00840437-DE	43.7	0.84	7.5	AX-RC03350219-DE	21.9	3.35
11.0	AX-RC00590614-DE	61.4	0.59	11.0	AX-RC02330307-DE	30.7	2.33
15.0	AX-RC00440859-DE	85.9	0.44	15.0	AX-RC01750430-DE	43.0	1.75
18.5 to 22	AX-RC00301275-DE	127.5	0.30	18.5 to 22	AX-RC01200644-DE	64.4	1.20
30	AX-RC00231662-DE	166.2	0.23	30	AX-RC00920797-DE	79.7	0.92
37	AX-RC00192015-DE	201.5	0.19	37	AX-RC00741042-DE	104.2	0.74
45	AX-RC00162500-DE	250.0	0.16	45	AX-RC00611236-DE	123.6	0.61
55	AX-RC00133057-DE	305.7	0.13	55	AX-RC00501529-DE	152.9	0.50

Output AC Reactor

200 V class				400 V class			
Max. applicable motor output kW	Reference	Current value A	Inductance mH	Max. applicable motor output kW	Reference	Current value A	Inductance mH
0.4	AX-RAO11500026-DE	2.6	11.50	0.4 to 1.5	AX-RAO16300038-DE	3.8	16.30
0.75	AX-RAO07600042-DE	4.2	7.60				
1.5	AX-RAO04100075-DE	7.5	4.10				
2.2	AX-RAO03000105-DE	10.5	3.00	2.2	AX-RAO11800053-DE	5.3	11.80
3.7	AX-RAO01830160-DE	16.0	1.83	4.0	AX-RAO07300080-DE	8.0	7.30
5.5	AX-RAO01150220-DE	22.0	1.15	5.5	AX-RAO04600110-DE	11.0	4.60
7.5	AX-RAO00950320-DE	32.0	0.95	7.5	AX-RAO03600160-DE	16.0	3.60
11	AX-RAO00630430-DE	43.0	0.63	11	AX-RAO02500220-DE	22.0	2.50
15	AX-RAO00490640-DE	64.0	0.49	15	AX-RAO02000320-DE	32.0	2.00

Braking Unit

Voltage	Reference	Specifications					
		Permanent		Peak (5s max)		Minimum connectable resistor (Ohms)	
		Current (A)	Brake power (kVA)	Current (A)	Brake power (kVA)		
200 V	AX-BCR2035090-TE	35	13	90	32	4	
	AX-BCR2070130-TE	70	25	130	47	2.8	
400 V	AX-BCR4015045-TE	15	11	45	33	16	
	AX-BCR4017068-TE	17	13	68	51	11	
	AX-BCR4035090-TE	35	26	90	67	8.5	
	AX-BCR4070130-TE	70	52	130	97	5.5	
	AX-BCR4090240-TE	90	67	240	180	3.2	

Ordering information

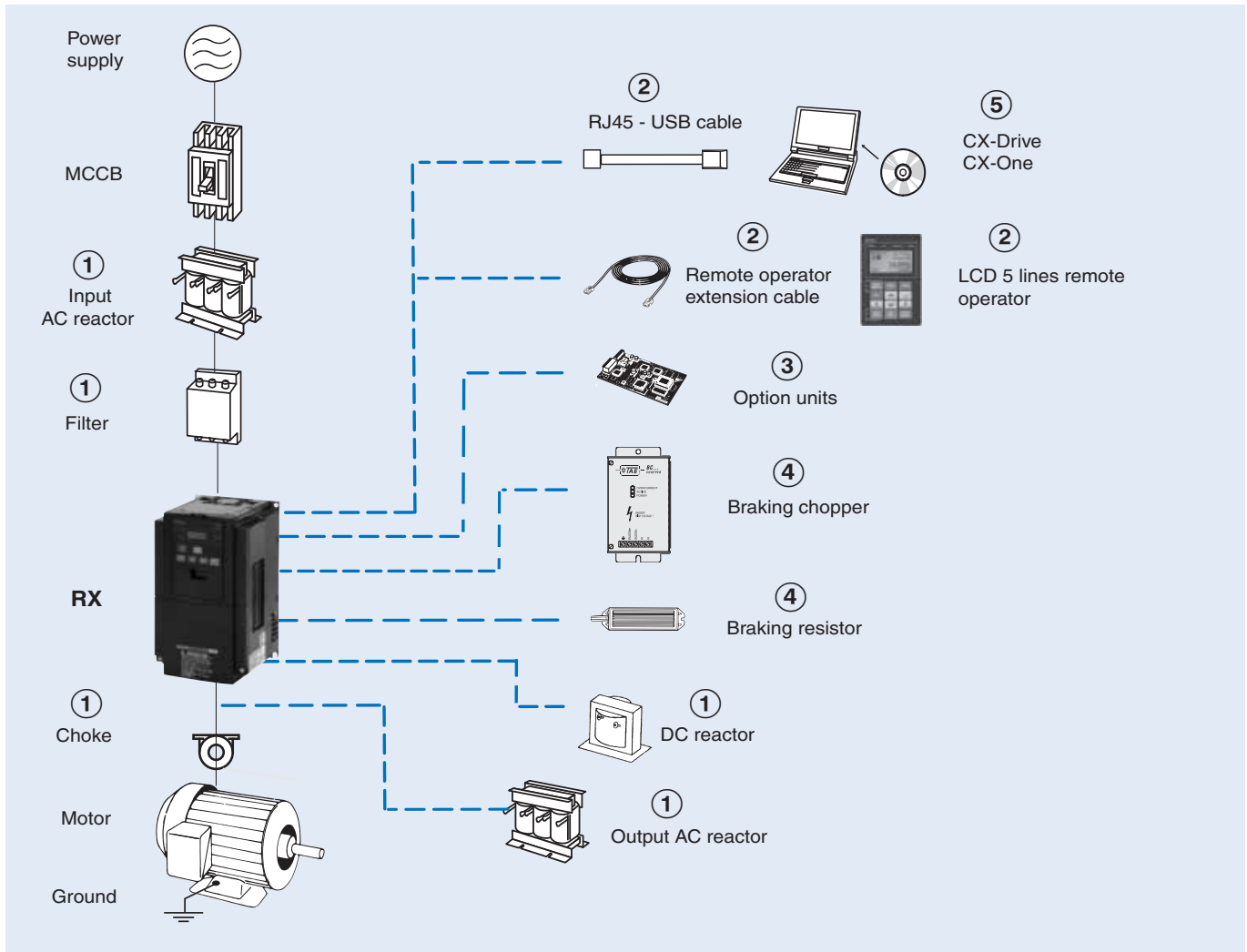

RX

Specifications			Model	Specifications			Model
Voltage class	Max motor kW	Rated current A	Standard	Voltage class	Max motor kW	Rated current A	Standard
Three-phase 200 V	0.4	3.0	RX-A2004-EF	Three-phase 400 V	0.4	1.5	RX-A4004-EF
	0.75	5.0	RX-A2007-EF		0.75	2.5	RX-A4007-EF
	1.5	7.5	RX-A2015-EF		1.5	3.8	RX-A4015-EF
	2.2	10.5	RX-A2022-EF		2.2	5.3	RX-A4022-EF
	4.0	16.5	RX-A2037-EF		4.0	9.0	RX-A4040-EF
	5.5	24	RX-A2055-EF		5.5	14	RX-A4055-EF
	7.5	32	RX-A2075-EF		7.5	19	RX-A4075-EF
	11	46	RX-A2110-EF		11	25	RX-A4110-EF
	15	64	RX-A2150-EF		15	32	RX-A4150-EF
	18.5	76	RX-A2185-EF		18.5	38	RX-A4185-EF
	22	95	RX-A2220-EF		22	48	RX-A4220-EF
	30	121	RX-A2300-EF		30	58	RX-A4300-EF
	37	145	RX-A2370-EF		37	75	RX-A4370-EF
	45	182	RX-A2450-EF		45	91	RX-A4450-EF
	55	220	RX-A2550-EF		55	112	RX-A4550-EF
-	-	-	-	75	149	RX-B4750-EF	
-	-	-	-	90	176	RX-B4900-EF	
-	-	-	-	110	217	RX-B411K-EF	
-	-	-	-	132	260	RX-B413K-EF	

① Line filters

Rasmi Line filter									
200V					400V				
Model RX-□	Reference	Rated current (A)	Leakage Nom / Max	Kg	Model RX-□	Reference	Rated current (A)	Leakage Nom / Max	Kg
A2004 / A2007/ A2015/ A2022 / A2037	AX-FIR2018-RE	18	0.7/40 mA	2.0	A4004/ A4007/ A4015/ A4022/ A4040	AX-FIR3010-RE	10	0.3/40 mA	1.9
A2055 / A2075 / A2110	AX-FIR2053-RE	53	0.7/40 mA	2.5	A4055 / A4075 / A4110	AX-FIR3030-RE	30	0.3/40 mA	2.2
A2150/ A2185/ A2220	AX-FIR2110-RE	110	1.2/70 mA	8.0	A4150/ A4185/ A4220	AX-FIR3053-RE	53	0.8/70 mA	4.5
A2300	AX-FIR2145-RE	145	1.2/70 mA	8.6	A4300	AX-FIR3064-RE	64	3/160 mA	7.0
A2370/ A2450	AX-FIR3250-RE	250	6/300 mA	13.0	A4370	AX-FIR3100-RE	100	2/130 mA	8.0
A2550	AX-FIR3320-RE	320	6/300 mA	13.2	A4450 / A4550	AX-FIR3130-RE	130	2/130 mA	8.6
					A4750 / A4900	AX-FIR3250-RE	250	10/500 mA	13.0
					A411K / A413K	AX-FIR3320-RE	320	10/500 mA	13.2

① Input AC Reactors

Voltage			
3-Phase 200 VAC		3-Phase 400 VAC	
Inverter Model RX-□	AC Reactor Reference	Inverter Model RX-□	AC Reactor Reference
A2004 / A2007 / A2015	AX-RAI02800100-DE	A4004 / A4007 / A4015	AX-RAI07700050-DE
A2022 / A2037	AX-RAI00880200-DE	A4022 / A4040	AX-RAI03500100-DE
A2055 / A2075	AX-RAI00350335-DE	A4055 / A4075	AX-RAI01300170-DE
A2110 / A2150	AX-RAI00180670-DE	A4110 / A4150	AX-RAI00740335-DE
A2185 / A2220	AX-RAI00091000-DE	A4185 / A4220	AX-RAI00360500-DE
A2300 / A2370	AX-RAI00071550-DE	A4300 / A4370	AX-RAI00290780-DE
A2450 / A2550	AX-RAI00042300-DE	A4450 / A4550	AX-RAI00191150-DE

① DC Reactors

Voltage			
3-Phase 200 VAC		3-Phase 400 VAC	
Inverter Model RX-□	AC Reactor Reference	Inverter Model RX-□	AC Reactor Reference
A2004	AX-RC10700032-DE	A4004	AX-RC43000020-DE
A2007	AX-RC06750061-DE	A4007	AX-RC27000030-DE
A2015	AX-RC03510093-DE	A4015	AX-RC14000047-DE
A2022	AX-RC02510138-DE	A4022	AX-RC10100069-DE
A2037	AX-RC01600223-DE	A4040	AX-RC06400116-DE
A2055	AX-RC01110309-DE	A4055	AX-RC04410167-DE
A2075	AX-RC00840437-DE	A4075	AX-RC03350219-DE
A2110	AX-RC00590614-DE	A4110	AX-RC02330307-DE
A2150	AX-RC00440859-DE	A4150	AX-RC01750430-DE
A2185 / A2220	AX-RC00301275-DE	A4185 / A4220	AX-RC01200644-DE
A2300	AX-RC00231662-DE	A4300	AX-RC00920797-DE
A2370	AX-RC00192015-DE	A4370	AX-RC00741042-DE
A2450	AX-RC00162500-DE	A4450	AX-RC00611236-DE
A2550	AX-RC00133057-DE	A4550	AX-RC00501529-DE

① Chokes

Model	Diameter	Description
AX-FER2102-RE	21	For 2.2 kW motors or below
AX-FER2515-RE	25	For 15 kW motors or below
AX-FER5045-RE	50	For 45 kW motors or below
AX-FER6055-RE	60	For 55 kW motors or above

① Output AC Reactor

Voltage			
200V		400V	
Model RX-□	Reference	Model RX-□	Reference
A2004	AX-RAO11500026-DE	A4004 / A4007 / A4015	AX-RAO16300038-DE
A2007	AX-RAO07600042-DE		
A2015	AX-RAO04100075-DE		
A2022	AX-RAO03000105-DE	A4022	AX-RAO11800053-DE
A2037	AX-RAO01830160-DE	A4040	AX-RAO07300080-DE
A2055	AX-RAO01150220-DE	A4055	AX-RAO04600110-DE
A2075	AX-RAO00950320-DE	A4075	AX-RAO03600160-DE
A2110	AX-RAO00630430-DE	A4110	AX-RAO02500220-DE
A2150	AX-RAO00490640-DE	A4150	AX-RAO02000320-DE

② Accessories

Types	Model	Description	Functions
Digital operator	AX-OP05-E	LCD remote operator	5 Line LCD remote operator with copy function, cable length max. 3m. ^{*1}
	3G3AX-CAJOP300-EE	Remote operator cable	3 meters cable for connecting remote operator
	3G3AX-OP01	LED remote operator	LED remote operator, cable length max. 3m
	4X-KITMINI	Mounting kit for LED operator	Mounting kit for LED operator on panel
Accessories	USB RJ45 RS422 CONV CABLE	USB converter / USB cable	RJ45 to USB connection cable

*1 please note, models with firmware 4287 and 4288, the operator will only display 2 lines of text.

③ Option boards

Types	Model	Description	Functions
Encoder Feedback	3G3AX-PG	PG speed controller option card	Phase A,B and Z pulse (differential pulse) inputs (RS-422) Pulse train position command input (RS-422) Pulse monitor output (RS-422) PG frequency range: 100 kHz max
Communication option board	SJ-DN	DeviceNet option card	Used for running or stopping the inverter or give frequency reference through DeviceNet
	SJ-PB	Profibus option card	Used for running or stopping the inverter or give frequency reference through Profibus
Digital input	SJ-DG	Digital input option card	Allows to set frequency reference from a digital selection

④ Braking unit, braking resistor unit

Voltage	Inverter				Braking resistor unit						
	Max. motor kW	Inverter RX □	Braking Unit AX-BCR □	Connectable min. resistance Ω	Inverter mounted type (3 %ED, 10 sec max)		Braking torque %	External resistor 10%ED 10 sec max for built-in 5 sec max for Braking Unit		Braking torque %	
		3-phase			Type AX-	Resist Ω		Type AX-	Resist Ω		
200 V (single-/three-phase)	0.55	2004	Built-in	50	REM00K1200-IE	200	180	REM00K1200-IE	200	180	
	1.1	2007			35	REM00K2070-IE	70	140	REM00K4075-IE	75	130
	1.5	2015		16		REM00K4075-IE	75	50	REM00K6035-IE	35	180
	2.2	2022			10	REM00K4035-IE	35	75	REM00K9020-IE	20	150
	4.0	2037		7.5		REM00K6035-IE	35	55	REM01K9017-IE	17	110
	5.5	2055			5	REM00K9017-IE	17	40	REM02K1017-IE	17	75
	7.5	2075		2035090-TE		REM00K9017-IE	17	55	REM03K5010-IE	10	95
	11.0	2110			2070130-TE	REM03K5010-IE	10	75	REM19K0008-IE	8	95
	15.0	2150		2035090-TE		4			180	REM19K0006-IE	6
	18.5	2185			2070130-TE					2.8	
	22.0	2220		2070130-TE		2.8			120		
	30.0	2300			2070130-TE					2.8	
	37.0	2370		2070130-TE		2.8			160		
	45.0	2450			2070130-TE					2.8	
55.0	2550	2070130-TE	2.8				200	2 x REM19K0006-IE	3		
400 V (three-phase)	0.55				4004			Built-in	100	REM00K1400-IE	400
	1.1	4007	70	REM00K1200-IE	200	190	REM00K2200-IE			200	190
	1.5	4015		35	REM00K2200-IE	200	130		REM00K5120-IE	120	200
	2.2	4022	24		REM00K2120-IE	120	120		REM00K6100-IE	100	140
	4.0	4040		20	REM00K4075-IE	75	140		REM00K9070-IE	70	150
	5.5	4055	4015045-TE		16	REM00K6100-IE	100		100	REM01K9070-IE	70
	7.5	4075		4017068-TE		11	REM00K9070-IE		70	50	REM02K1070-IE
	11.0	4110	4035090-TE		8.5		REM00K9070-IE		70	55	REM03K5035-IE
	15.0	4150		4070130-TE		5.5	REM03K5035-IE		35	90	REM19K0030-IE
	18.5	4185	4090240-TE		3.2					75	REM19K0030-IE
	22.0	4220		4090240-TE		3.2					
	30.0	4300	4090240-TE		3.2					120	
	37.0	4370		4090240-TE		3.2					
	45.0	4450	4090240-TE		3.2					160	
	55.0	4550		4090240-TE		3.2					
	75.0	4750	4090240-TE		3.2					200	
	90.0	4900		4090240-TE		3.2					
	110.0	411K	4090240-TE		3.2					240	
132.0	413K	4090240-TE		3.2							260

⑤ Computer software

Types	Model	Description	Installation
Software	CX-drive	Computer software	Configuration and monitoring software tool
	CX-One	Computer software	Configuration and monitoring software tool



Qniesz ING Krzysztof Kunisz

05-124 Janówek Pierwszy, ul. Nowodworska 96

tel./fax: +48 22 750 51 36, tel.kom: +48 508 100 781

adres e-mail : Qniesz@Qniesz.pl

www.qniesz.pl

ALL DIMENSIONS SHOWN ARE IN MILLIMETERS.

To convert millimeters into inches, multiply by 0.03937. To convert grams into ounces, multiply by 0.03527.