

Charakterystyka wykonania:

- moce znamionowe podane są dla pracy S1,
- napięcie znamionowe 380, 400 lub 500 [V],
- częstotliwość napięcia zasilania 50 lub 60 [Hz],
- temperatura otoczenia od -15 do +40[°C],
- wysokość instalowania do 1000 [m] n.p.m.,
- izolacja klasy F,
- stopień ochrony IP 55,
- z jednym czopem końcowym wału wg rysunku wymiarowego,
- skrzynka zaciskowa z dławnicami i tabliczką 6-zaciskową,
- hamulec prądu stałego zasilany z prostownika podłączonego do tabliczki zaciskowej silnika.

Wykonania na życzenia:

- z termistorowymi czujnikami temperatury w czołach uzwojenia,
- przystosowane do pracy w klimacie tropikalnym TH, TA lub MT (w wykonaniu TA lub MT ze względu na podwyższone temperatury otoczenia obowiązuje obniżka mocy znamionowej),
- z niezależnym zasilaniem hamulca,
- z dźwignią do ręcznego zwalniania hamulca, oznaczenie „Y” na końcu typu silnika,
- fabryka wykonuje również silniki różniące się od wykonania podstawowego po uprzednim uzgodnieniu szczegółów konstrukcyjnych i terminów dostaw.

Sposób zamawiania:

- W zamówieniu należy podać pełne określenie typu silnika, moc, prędkość obrotową, napięcie zasilające, układ połączeń, częstotliwość, formę wykonania, napięcie zasilania hamulca w przypadku zasilania niezależnego oraz inne szczegóły niekatalogowego lub specjalnego wykonania.

Features:

- rated outputs for continuous duty,
- rated voltage 380, 400 or 500 [V],
- frequency 50 or 60 [Hz],
- environment temperature -15 to +40[°C],
- altitude up to 1000 [m] above sea level,
- insulation class F,
- protection degree IP 55,
- one free shaft extension according to dimension drawing,
- terminal box with glands and 6 terminal board with 6 terminals,
- rectifier - powered brake of direct current connected to terminal box.

Features on request:

- temperature - sensitive resistors in the winding ends,
- fit for work in tropical climate TH, TA or MT (for TA or MT rated output is decreased due to higher environment temperature),
- with brake independently supplied,
- with lever for manual releasing of brake, „Y” added to the motor marking,
- factory produces various types of motors but constructional details and delivery time are to be individual agreed.

How to order:

- In the order there must be clearly given: full designation of the motor, rated output, rated speed, rated voltage, phase connection, frequency, mounting form, voltage of brake's supply in case of independent supply and all details for non catalogue execution.

PARAMETRY EKSPLOATACYJNE SILNIKÓW PERFORMANCES OF MOTORS

Typ silnika	P_n		n_n	η_n	$\cos\phi_n$	I_{In} przy nap. znam.			m_{rn}	i_{rn}	m_{maxn}	J	Masa IM B3	Typ hamulca	Moment hamujący hamulca
Type of motor	Rated output		Rated speed	Efficiency	Power factor	Full-load amps at			Locked rotor torque	Locked rotor current	Break down torque	Moment of inertia	Weight IM B3	Type brake	Breaking torque
	[kW]	[HP]	[min ⁻¹]	[%]	-	[A] 380V	[A] 400V	[A] 500V	[%]	[%]	[%]	[kgm ²]	[kg]	-	[Nm]
2p=2 $n_s=3000$ obr/min rpm=3000															
Sh 90S-2-HS(Y)	1,5	2,0	2835	81,1	0,83	3,4	3,2	2,6	300	615	305	0,0014	18,5	HPS 10	16
Sh 90L-2-HS(Y)	2,2	3,0	2855	83,2	0,82	4,9	4,7	3,7	340	710	350	0,0021	21,5	HPS 10	16
Sg 100L-2-HS(Y)	3,0	4,0	2905	83,4	0,86	6,4	6,1	4,9	270	750	280	0,0050	32,0	HPS 12	32
Sg 112M-2-HS(Y)	4,0	5,5	2865	85,4	0,9	7,9	7,5	6,0	210	640	230	0,0081	43,5	HPS 14	60
Sg 132S-2A-HS(Y)	5,5	7,5	2910	87,0	0,88	10,9	10,4	8,3	240	700	320	0,0190	71,0	HPS 16	80
Sg 132S-2B-HS(Y)	7,5	10,0	2920	88,5	0,88	14,6	13,9	11,1	250	750	320	0,0160	82,0	HPS 16	80
Sg 160M-2A-HS(Y)	11,0	15,0	2930	89,5	0,89	20,9	19,9	15,9	240	610	290	0,0630	115,0	HPS 18	150
Sg 160M-2B-HS(Y)	15,0	20,0	2920	90,5	0,91	27,6	26,2	21,0	240	620	270	0,0570	130,0	HPS 18	150
Sg 180M-2-HS(Y)	22,0	30,0	2920	90,6	0,88	42,5	40,4	32,3	250	600	250	0,0780	190,0	HPS 20	240
2p=4 $n_s=1500$ obr/min rpm=1500															
Sh 90S-4-HS(Y)	1,1	1,5	1405	76,7	0,80	2,7	2,6	2,1	220	490	280	0,0024	18,5	HPS 10	16
Sh 90L-4-HS(Y)	1,5	2,0	1410	79,0	0,78	3,7	3,5	2,8	250	530	280	0,0029	20,8	HPS 10	16
Sg 100L-4A-HS(Y)	2,2	3,0	1425	82,0	0,80	5,1	4,8	3,9	250	610	280	0,0059	30,0	HPS 12	32
Sg 100L-4B-HS(Y)	3,0	4,0	1415	81,5	0,81	6,9	6,6	5,2	260	610	270	0,0067	33,0	HPS 12	32
Sg 112M-4-HS(Y)	4,0	5,5	1435	85,1	0,82	8,7	8,3	6,6	260	630	300	0,0120	43,5	HPS 14	60
Sg 132S-4-HS(Y)	5,5	7,5	1450	85,9	0,84	11,6	11,0	8,8	220	690	310	0,0300	63,0	HPS 16	80
Sg 132M-4-HS(Y)	7,5	10,0	1450	87,0	0,85	15,4	14,6	11,7	240	670	310	0,0360	85,0	HPS 16	80
Sg 160M-4-HS(Y)	11,0	15,0	1460	89,0	0,85	22,0	20,9	16,7	230	700	310	0,0760	120,0	HPS 18	150
Sg 160L-4-HS(Y)	15,0	20,0	1460	89,5	0,87	29,2	27,7	22,2	240	730	320	0,0760	145,0	HPS 18	150
Sg 180M-4-HS(Y)	18,5	25,0	1470	90,5	0,90	34,5	32,8	26,2	240	680	290	0,1370	190,0	HPS 20	240
Sg 180L-4-HS(Y)	22,0	30,0	1465	91,0	0,90	40,8	38,8	31,0	270	730	280	0,1570	200,0	HPS 20	240
2p=6 $n_s=1000$ obr/min rpm=1000															
Sh 90S-6-HS(Y)	0,75	1,0	915	72,4	0,72	2,2	2,1	1,7	190	370	220	0,0021	17,7	HPS 10	16
Sh 90L-6-HS(Y)	1,10	1,5	920	75,4	0,71	3,1	2,9	2,4	220	400	225	0,0029	22,4	HPS 10	16
Sg 100L-6-HS(Y)	1,50	2,0	945	76,7	0,73	4,1	3,9	3,1	190	460	230	0,0091	29,0	HPS 12	32
Sg 112M-6-HS(Y)	2,20	3,0	960	83,8	0,78	5,1	4,8	3,9	220	590	280	0,0179	42,5	HPS 14	60
Sg 132S-6-HS(Y)	3,00	4,0	950	81,0	0,78	7,2	6,8	5,5	210	540	280	0,0260	68,0	HPS 16	80
Sg 132M-6A-HS(Y)	4,00	5,5	950	84,0	0,79	9,1	8,6	6,9	240	600	310	0,0330	78,0	HPS 16	80
Sg 132M-6B-HS(Y)	5,50	7,5	950	85,0	0,79	12,4	11,8	9,4	270	630	310	0,0410	84,0	HPS 16	80
Sg 160M-6-HS(Y)	7,50	10,0	960	87,5	0,81	16,0	15,2	12,2	230	650	310	0,0730	115,0	HPS 18	150
Sg 160L-6-HS(Y)	11,0	15,0	960	88,5	0,82	23,0	21,9	17,5	240	700	310	0,0970	150,0	HPS 18	150
Sg 180L-6-HS(Y)	15,0	20,0	975	89,0	0,84	30,5	29,0	23,2	280	600	240	0,2220	195,0	HPS 20	240
2p=8 $n_s=750$ obr/min rpm=750															
Sh 90S-8-HS(Y)	0,37	0,50	695	63,4	0,59	1,5	1,4	1,1	170	295	230	0,0022	17,7	HPS 10	16
Sh 90L-8-HS(Y)	0,55	0,75	675	65,0	0,64	2,0	1,9	1,5	170	280	190	0,0025	19,5	HPS 10	16
Sg 100L-8A-HS(Y)	0,75	1,00	710	71,1	0,66	2,4	2,3	1,8	145	350	190	0,0091	28,5	HPS 12	32
Sg 100L-8B-HS(Y)	1,10	1,50	705	72,2	0,65	3,6	3,4	2,7	160	360	190	0,0101	31,5	HPS 12	32
Sg 112M-8-HS(Y)	1,50	2,00	720	76,8	0,71	4,2	4,0	3,2	190	460	230	0,0194	38,5	HPS 14	60
Sg 132S-8-HS(Y)	2,20	3,00	710	78,0	0,74	5,8	5,5	4,4	200	470	240	0,0340	65,0	HPS 16	80
Sg 132M-8-HS(Y)	3,00	4,00	710	80,0	0,74	7,7	7,3	5,9	230	500	300	0,0450	77,0	HPS 16	80
Sg 160M-8A-HS(Y)	4,00	5,50	705	81,5	0,76	9,8	9,3	7,4	220	500	270	0,0610	100,0	HPS 18	150
Sg 160M-8B-HS(Y)	5,50	7,50	710	83,0	0,75	13,4	12,7	10,2	270	550	300	0,0780	110,0	HPS 18	150
Sg 160L-8-HS(Y)	7,50	10,0	705	84,5	0,78	17,2	16,3	13,1	270	580	300	0,1030	130,0	HPS 18	150
Sg 180L-8-HS(Y)	11,0	15,0	730	89,0	0,76	24,7	23,5	18,8	200	550	240	0,2150	190,0	HPS 20	240

Wymiary montażowe silników na łapach Mounting dimensions for foot-mounted motors

Typ Type	A	B	C	D	E	F	GA	H	K
	[mm]								
Sh 90S-...-HS(Y)	140	100	56	24j6	50	8h9	27,0	90	10
Sh 90L-...-HS(Y)	140	125	56	24j6	50	8h9	27,0	90	10
Sg 100L-...-HS(Y)	160	140	63	28j6	60	8h9	31,0	100	12
Sg 112M-...-HS(Y)	190	140	70	28j6	60	8h9	31,0	112	12
Sg 132S-...-HS(Y)	216	140	89	38k6	80	10h9	41,0	132	12
Sg 132M-...-HS(Y)	216	178	89	38k6	80	10h9	41,0	132	12
Sg 160M-...-HS(Y)	254	210	108	42k6	110	12h9	45,0	160	15
Sg 160L-...-HS(Y)	254	254	108	42k6	110	12h9	45,0	160	15
Sg 180M-...-HS(Y)	279	241	121	48k6	110	14h9	51,5	180	15
Sg 180L-...-HS(Y)	279	279	121	48k6	110	14h9	51,5	180	15

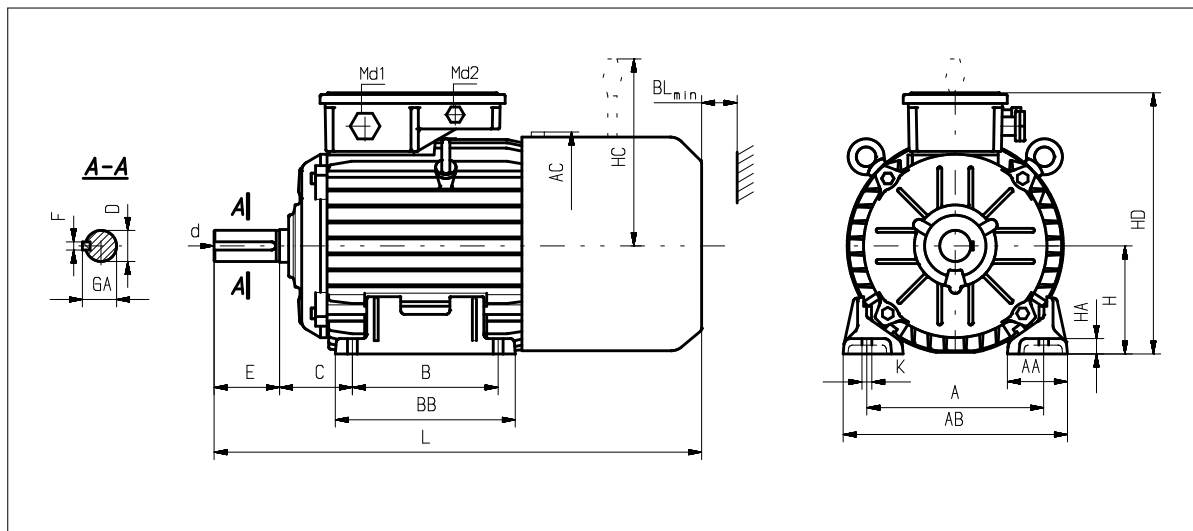

Wymiary gabarytowe silników na łapach Overall dimensions for foot-mounted motors

Typ Type	AA	AB	AC	BB	BL	d	HA	HC	HD	L	Md1	Md2	Łożysko nr Bearing No
	[mm]												
Sh 90S-...-HS(Y)	50	170	185	153	15	M8	10	170	232	388	M 20 x 1,5	M16 x 1,5	6205 2Z
Sh 90L-...-HS(Y)	50	170	185	153	15	M8	10	170	232	413	M 20 x 1,5	M16 x 1,5	6205 2Z
Sg 100L-...-HS(Y)	45	200	206	172	20	M10	14	184	253	475	M 20 x 1,5	M16 x 1,5	6206 2Z
Sg 112M-...-HS(Y)	54	230	245	174	20	M10	14	191	286	508	M 25 x 1,5	M16 x 1,5	6306 2Z
Sg 132S-...-HS(Y)	56	278	274	182	40	M12	16	204	319	567	M 25 x 1,5	M16 x 1,5	6308 2Z
Sg 132S-2B-HS(Y)	56	278	274	220	40	M12	16	204	319	605	M 25 x 1,5	M16 x 1,5	6308 2Z
Sg 132M-...-HS(Y)	56	278	274	220	40	M12	16	204	319	605	M 25 x 1,5	M16 x 1,5	6308 2Z
Sg 160M-...-HS(Y)	60	305	323	256	40	M16	20	230	367	724	M 40 x 1,5	M16 x 1,5	6309 2Z
Sg 160L-...-HS(Y)	60	305	323	300	40	M16	20	230	367	768	M 40 x 1,5	M16 x 1,5	6309 2Z
Sg 180M-...-HS(Y)	70	350	360	320	40	M16	26	270	406	838	M 40 x 1,5	M16 x 1,5	6311 2Z
Sg 180L-...-HS(Y)	70	350	360	320	40	M16	26	270	406	838	M 40 x 1,5	M16 x 1,5	6311 2Z

Wymiar AB dla silników wielkości 132 z łapami odlewanymi wraz z korpusem wynosi 260 mm.

Wymiar HC dotyczy silników z dźwignią do ręcznego zwalniania hamulca (oznaczenie „Y” na końcu typu silnika).

As to motors of size "132" the dimension AB amounts to 260 mm in case the feet are together with frame casted.

The dimension HC concerns the motors with manual releasing of brake („Y” added to the motor marking).

Formy wykonania:

- IM 1001, IM 1011, IM 1031, IM 1051, IM 1061, IM 1071 - wg IEC 34-7, PN-EN 60034-7
- IM B3, IM B6, IM B7, IM B8, IM V5, IM V6 - wg IEC 34-7, PN-EN 60034-7

Mounting forms:

- IM 1001, IM 1011, IM 1031, IM 1051, IM 1061, IM 1071 - per IEC 34-7, PN-EN 60034-7
- IM B3, IM B6, IM B7, IM B8, IM V5, IM V6 - per IEC 34-7, PN-EN 60034-7

Wymiary montażowe silników kolnierowych Mounting dimensions for flange-mounted motors

Typ Type	D	E	F	GA	M	N	P	S	T
	[mm]								
SKh 90S-...-HS(Y)	24j6	50	8h9	27,0	165	130j6	200	12	3,5
SKh 90L-...-HS(Y)	24j6	50	8h9	27,0	165	130j6	200	12	3,5
SKg 100L-...-HS(Y)	28j6	60	8h9	31,0	215	180j6	250	15	4,0
SKg 112M-...-HS(Y)	28j6	60	8h9	31,0	215	180j6	250	15	4,0
SKg 132S-...-HS(Y)	38k6	80	10h9	41,0	265	230j6	300	15	4,0
SKg 132M-...-HS(Y)	38k6	80	10h9	41,0	265	230j6	300	15	4,0
SKg 160M-...-HS(Y)	42k6	110	12h9	45,0	300	250j6	350	19	5,0
SKg 160L-...-HS(Y)	42k6	110	12h9	45,0	300	250j6	350	19	5,0
SKg 180M-...-HS(Y)	48k6	110	14h9	51,5	300	250j6	350	19	5,0
SKg 180L-...-HS(Y)	48k6	110	14h9	51,5	300	250j6	350	19	5,0

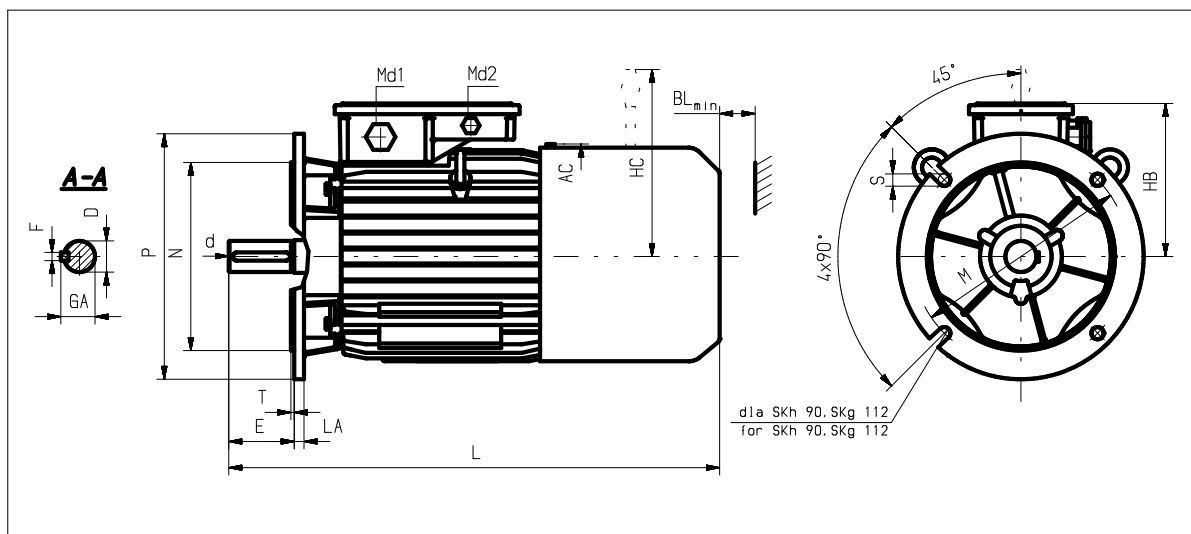

Wymiary gabarytowe silników kolnierowych Overall dimensions for flange-mounted motors

Typ Type	AC	BL	d	HB	HC	L	LA	Md1	Md2	Łożyisko nr Bearing No
	[mm]									
SKh 90S-...-HS(Y)	185	15	M8	142	170	388	8	M 20 x 1,5	M16 x 1,5	6205 2Z
SKh 90L-...-HS(Y)	185	15	M8	142	170	413	8	M 20 x 1,5	M16 x 1,5	6205 2Z
SKg 100L-...-HS(Y)	206	20	M10	153	184	475	11	M 20 x 1,5	M16 x 1,5	6206 2Z
SKg 112M-...-HS(Y)	245	20	M10	174	191	508	12	M 25 x 1,5	M16 x 1,5	6306 2Z
SKg 132S-...-HS(Y)	274	40	M12	187	204	567	12	M 25 x 1,5	M16 x 1,5	6308 2Z
SKg 132S-2B-HS(Y)	274	40	M12	187	204	605	12	M 25 x 1,5	M16 x 1,5	6308 2Z
SKg 132M-...-HS(Y)	274	40	M12	187	204	605	12	M 25 x 1,5	M16 x 1,5	6308 2Z
SKg 160M-...-HS(Y)	323	40	M16	207	230	724	13	M 40 x 1,5	M16 x 1,5	6309 2Z
SKg 160L-...-HS(Y)	323	40	M16	207	230	768	13	M 40 x 1,5	M16 x 1,5	6309 2Z
SKg 180M-...-HS(Y)	360	40	M16	226	270	838	13	M 40 x 1,5	M16 x 1,5	6311 2Z
SKg 180L-...-HS(Y)	360	40	M16	226	270	838	13	M 40 x 1,5	M16 x 1,5	6311 2Z

Wymiar HC dotyczy silników z dźwignią do ręcznego zwalniania hamulca (oznaczenie „Y” na końcu typu silnika).
The dimension HC concerns the motors with manual releasing of brake („Y” added to the motor marking).

Formy wykonania:

- IM 3001, IM 3011, IM 3031 - wg IEC 34-7, PN-EN 60034-7
- IM B5, IM V1, IM V3 - wg IEC 34-7, PN-EN 60034-7

Mounting forms:

- IM 3001, IM 3011, IM 3031 - per IEC 34-7, PN-EN 60034-7
- IM B5, IM V1, IM V3 - per IEC 34-7, PN-EN 60034-7

Wymiary montażowe silników kołnierowych na łapach Mounting dimensions for foot-flange-mounted motors

Typ Type	A	B	C	D	E	F	GA	H	K	M	N	P	S	T
	[mm]													
SLh 90S-...-HS(Y)	140	100	56	24j6	50	8h9	27,0	90	10	165	130j6	200	12	3,5
SLh 90L-...-HS(Y)	140	125	56	24j6	50	8h9	27,0	90	10	165	130j6	200	12	3,5
SLg 100L-...-HS(Y)	160	140	63	28j6	60	8h9	31,0	100	12	215	180j6	250	15	4,0
SLg 112M-...-HS(Y)	190	140	70	28j6	60	8h9	31,0	112	12	215	180j6	250	15	4,0
SLg 132S-...-HS(Y)	216	140	89	38k6	80	10h9	41,0	132	12	265	230j6	300	15	4,0
SLg 132M-...-HS(Y)	216	178	89	38k6	80	10h9	41,0	132	12	265	230j6	300	15	4,0
SLg 160M-...-HS(Y)	254	210	108	42k6	110	12h9	45,0	160	15	300	250j6	350	19	5,0
SLg 160L-...-HS(Y)	254	254	108	42k6	110	12h9	45,0	160	15	300	250j6	350	19	5,0
SLg 180M-...-HS(Y)	279	241	121	48k6	110	14h9	51,5	180	15	300	250j6	350	19	5,0
SLg 180L-...-HS(Y)	279	279	121	48k6	110	14h9	51,5	180	15	300	250j6	350	19	5,0

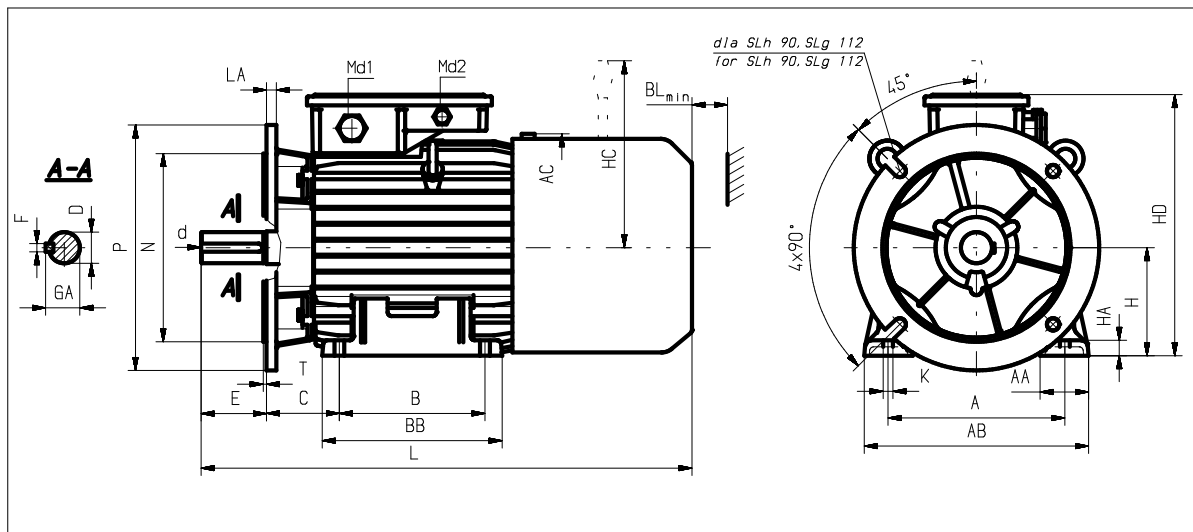

Wymiary gabarytowe silników kołnierowych na łapach Overall dimensions for foot-flange-mounted motors

Typ Type	AA	AB	AC	BB	BL	d	HA	HC	HD	L	LA	Md1	Md2	Łożysko nr Bearing No
	[mm]													
SLh 90S-...-HS(Y)	50	170	185	153	15	M8	10	170	232	388	8	M 20 x 1,5	M16 x 1,5	6205 2Z
SLh 90L-...-HS(Y)	50	170	185	153	15	M8	10	170	232	413	8	M 20 x 1,5	M16 x 1,5	6205 2Z
SLg 100L-...-HS(Y)	45	200	206	172	20	M10	14	184	253	475	11	M 20 x 1,5	M16 x 1,5	6206 2Z
SLg 112M-...-HS(Y)	54	230	245	174	20	M10	14	191	286	508	12	M 25 x 1,5	M16 x 1,5	6306 2Z
SLg 132S-...-HS(Y)	56	278	274	182	40	M12	16	204	319	567	12	M 25 x 1,5	M16 x 1,5	6308 2Z
SLg 132S-2B-...-HS(Y)	56	278	274	220	40	M12	16	204	319	605	12	M 25 x 1,5	M16 x 1,5	6308 2Z
SLg 132M-...-HS(Y)	56	278	274	220	40	M12	16	204	319	605	12	M 25 x 1,5	M16 x 1,5	6308 2Z
SLg 160M-...-HS(Y)	60	305	323	256	40	M16	20	230	367	724	13	M 40 x 1,5	M16 x 1,5	6309 2Z
SLg 160L-...-HS(Y)	60	305	323	300	40	M16	20	230	367	768	13	M 40 x 1,5	M16 x 1,5	6309 2Z
SLg 180M-...-HS(Y)	70	350	360	320	40	M16	26	270	406	838	13	M 40 x 1,5	M16 x 1,5	6311 2Z
SLg 180L-...-HS(Y)	70	350	360	320	40	M16	26	270	406	838	13	M 40 x 1,5	M16 x 1,5	6311 2Z

Wymiar AB dla silników wielkości 132 z łapami odlewanymi wraz z korpusem wynosi 260 mm.

Wymiar HC dotyczy silników z dźwignią do ręcznego zwalniania hamulca (oznaczenie „Y” na końcu typu silnika).

As to motors of size "132" the dimension AB amounts to 260 mm in case the feet are together with frame casted.

The dimension HC concerns the motors with manual releasing of brake („Y” added to the motor marking).

Formy wykonania:

■ IM 2001, IM 2011, IM 2031 - wg IEC 34-7, PN-EN 60034-7

■ IM B35, IM V15, IM V36 - wg IEC 34-7, PN-EN 60034-7

Mounting forms:

■ IM 2001, IM 2011, IM 2031 - per IEC 34-7, PN-EN 60034-7

■ IM B35, IM V15, IM V36 - per IEC 34-7, PN-EN 60034-7